



Food Grade Manufacturing

CM5 CURD MILL

SUITABLE FOR

DAIRY, OIL, CHEESE WHEY, CANNING,
FRUIT, JUICE, PAPER, SOY BEAN, CHEMICAL,
SUGAR, TEXTILE, PHARMACEUTICAL, MEAT

- Easy Rotor & Screen Removal
- Built-in Clean-in-place spray units
- Robust, Long Life
- All Stainless Steel

Developed for the food industry the RH Industrial CM5 Curd Mill is adaptable to many other industries where particle sizing is required. The mill is designed to have different size screens fitted for different particle sizing.



REID & HARRISON™
Industrial

www.dairypumpingsystems.com.au

Food Grade & Manufacturing

CM5 CURD MILL

Specification_RHIND_Curd_v24

FEATURES & BENEFITS

Robust, Long Life

Because of its robust construction, the CM5 Mill will be operating effectively long after other sizing mills have been replaced

Stainless Steel

All product contact and wash down surfaces are stainless steel, finished and polished to a standard that makes cleaning easy

Bearing Design

The CM5 Mill has a rotor shaft supported by a robust external bearing housing, fitted at the top. As there is no bearing assembly at the base, removing the rotor and screen is a simple operation.

CIP cleaned

The CM5 Mill has its own built in Clean In Place spray units, meaning the mill is completely cleaned using the factory's CIP system.

TECHNICAL SPECIFICATIONS

Model	CM5 Curd Mill
Capacity (10mm screen)	5000 kg / hr
Drive Motor	18.5kW 4pole 3phase
Screen Sizes	8mm & 10mm (other sizes available)
Inlet Fitting	4" Male RJT
Outlet Fitting	4" Male RJT
CIP Fitting	1" Male RJT
Operating RPM	Nom. 1100
Shipping Weight	Approx. 1000Kg.

Note Reid & Harrison reserve the right to change the specifications at any time without notice.

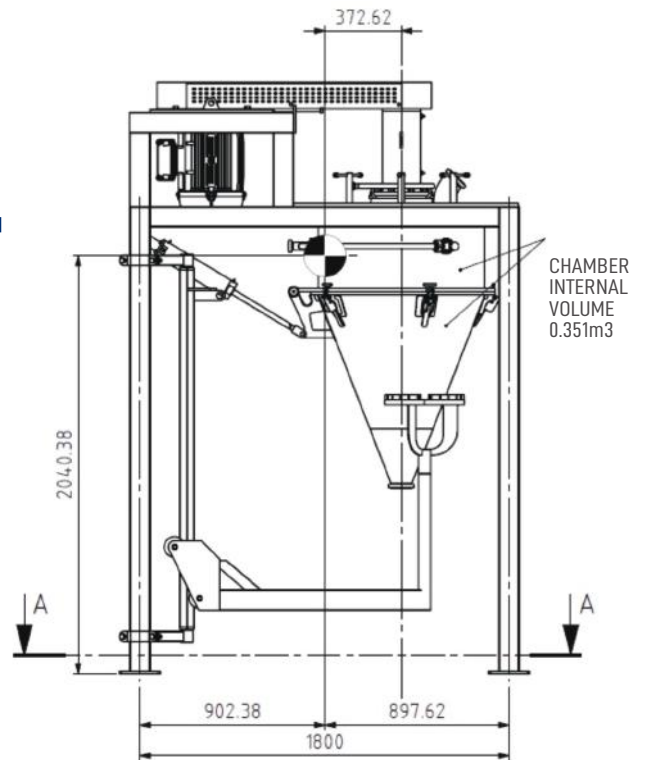

Dimensions

